

F3J/F6J Tee Junction Block

Provides a branch connection for SAE 4-bolt flanges or split flange heads.



F3J and F6J tee junction blocks offer a 4-bolt companion (flat face) SAE UNC connection on opposing faces and either the same 4-bolt companion (flat face) SAE UNC connection or a 4-bolt standard SAE O-Ring connection on the 90° branch face.

- Versions for SAE Code 61 and SAE Code 62.
- Carbon steel or stainless steel construction.
- 4-bolt companion (flat face) SAE UNC - always on opposing faces.
- Choice of either 4-bolt companion (flat face) SAE UNC flange or 4-bolt standard SAE O-ring flange on the branch face.
- Simplifies hydraulic line connectivity.
- Supplied with 3 O-Rings.

Ordering Codes Summary

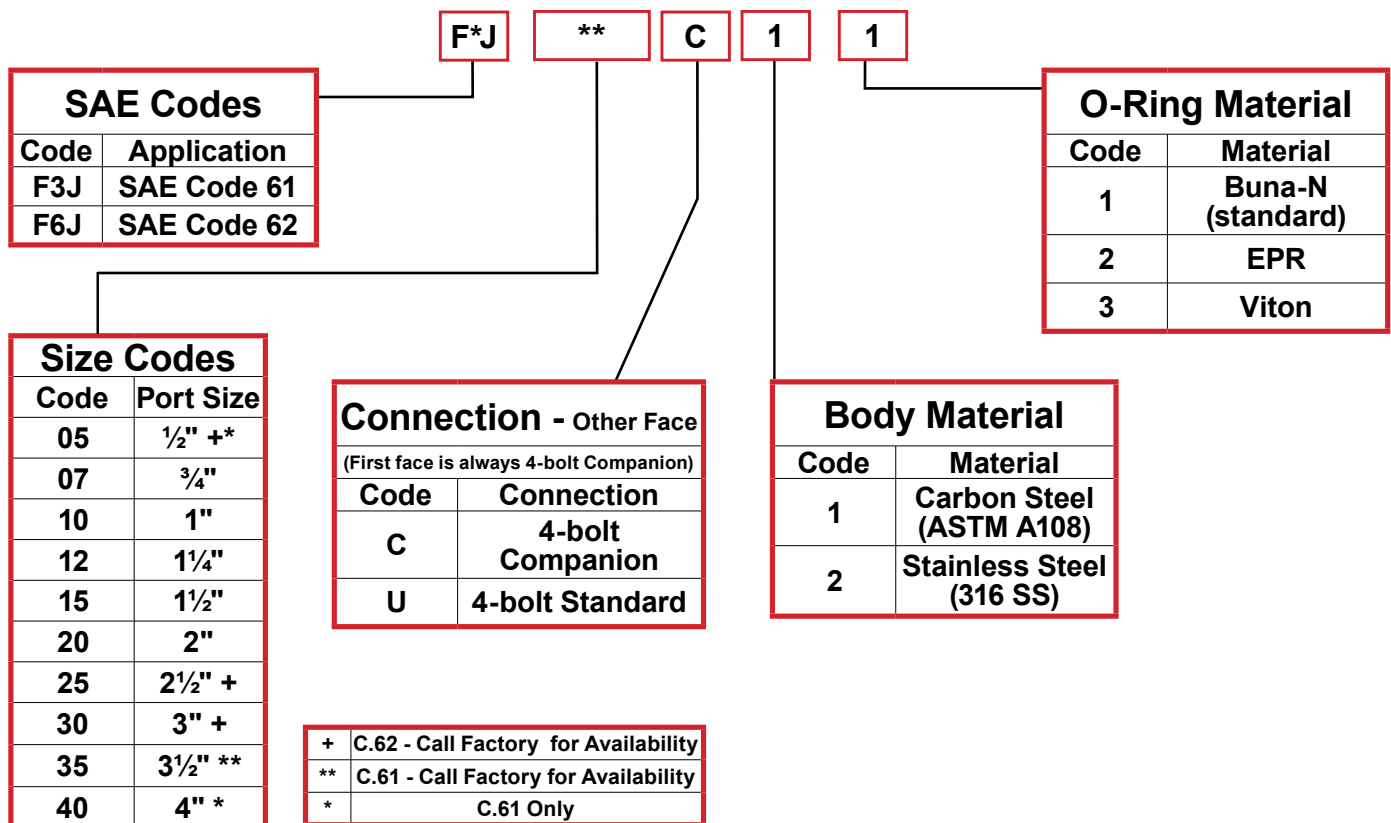

F3J/F6J Tee Junction Block

F3J Code 61 Tee Junction Block Dimensions

Dimensions (in)	Working PSI	A	B	C	D	E	F	G	H	J	K	L
Pad Size		Overall Width	Overall Height	Overall Thickness	FLG Pad Long	FLG Pad Short	Top To Center	Front To Center	O-Ring No.	Bore Size	Clearance Hole	UNC THD
05	5,000 PSI	2.25	2.75	2.22	1.50	0.69	1.38	1.22	2-210	0.50	0.33	5/16
07		3.00	3.25	2.47	1.87	0.87	1.63	1.31	2-214	0.75	0.33	3/8
10		3.00	3.50	2.97	2.06	1.03	1.75	1.69	2-219	1.00	0.40	3/8
12	4,000 PSI	3.50	4.00	3.47	2.31	1.19	2.00	1.94	2-222	1.25	0.47	7/16
15	3,000 PSI	4.00	4.25	3.97	2.75	1.41	2.13	2.25	2-225	1.50	0.53	1/2
20		4.50	4.50	4.47	3.06	1.69	2.25	2.44	2-228	2.00	0.53	1/2
25	2,500 PSI	4.50	4.75	4.47	3.50	2.00	2.38	2.25	2-232	2.50	0.53	1/2
30	2,000 PSI	5.50	5.50	5.47	4.19	2.44	2.75	2.78	2-237	3.00	0.66	5/8
35	500 PSI	6.00	6.00	5.97	4.75	2.75	3.00	3.13	2-241	3.50	0.66	5/8
40		6.50	6.50	6.47	5.13	3.06	3.25	3.38	2-245	4.00	0.66	5/8

F6J Code 62 Tee Junction Block Dimensions

Dimensions (in)	Working PSI	A	B	C	D	E	F	G	H	J	K	L
Pad Size		Overall Width	Overall Height	Overall Thickness	FLG Pad Long	FLG Pad Short	Top To Center	Front To Center	O-Ring No.	Bore Size	Clearance Hole	UNC THD
05	6,000 PSI	2.50	2.88	2.47	1.59	0.72	1.44	1.44	2-210	0.50	0.33	5/16
07		3.00	3.38	2.97	2.00	0.94	1.69	1.63	2-214	0.75	0.40	3/8
10		3.50	4.00	3.47	2.25	1.09	2.00	2.00	2-219	1.00	0.47	7/16
12		4.00	4.00	3.47	2.63	1.25	2.00	1.84	2-222	1.25	0.53	1/2
15		4.50	5.13	4.47	3.13	1.44	2.56	2.50	2-225	1.50	0.66	5/8
20		5.50	5.75	4.97	3.81	1.75	2.88	2.63	2-228	2.00	0.78	3/4
25		7.00	7.50	6.97	4.87	2.31	3.75	3.94	2-228	2.50	0.91	7/8
30		8.00	9.00	7.97	6.00	2.81	4.50	4.44	2-228	3.00	1.16	1 1/8

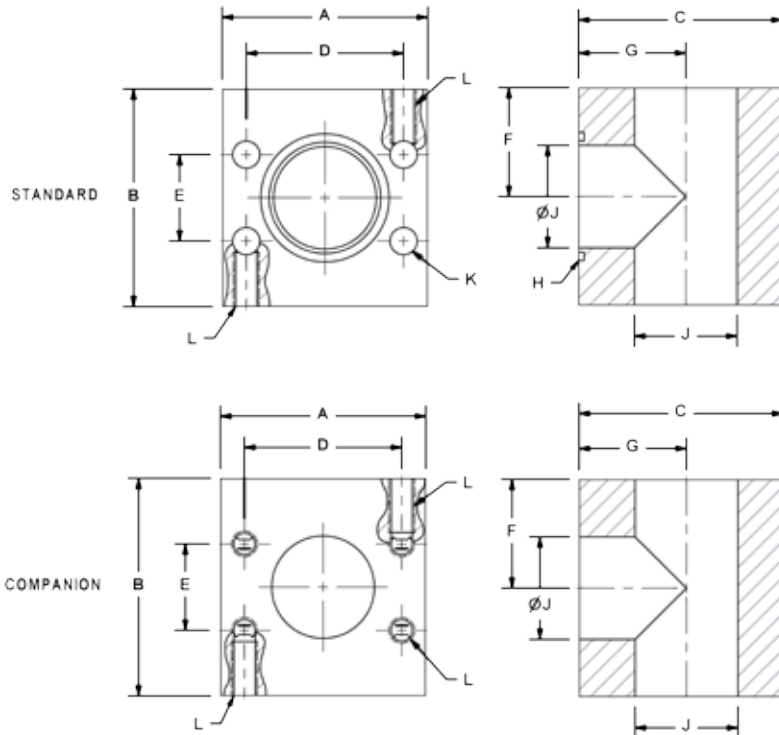

Note: Changes from Standard Materials may result in changes to temperature and/or pressure rating. Due to our policy of continual product improvement, the specifications in this catalog may change without notice. When designing by spec, please request a certified print.

